

DEVICE DESIGNATIONS

- AT Main control
- B Proximity switch
- BQ Encoder
- C Capacitor
- FU Fuse block
- KM Control master relay
- HL Pilot light
- L Filter suppressor
- M Motor
- PA Ampermeter
- QM Circuit breaker
- RP Potentiometer
- SA Selector switch
- SB Pushbutton
- SQ Limit switch
- ST Thermic switch
- TC Control circuit transformer
- TV Voltage transformer
- U Controller A.C.
- V Rectifier diode
- VC Rectifier bridge
- X Terminal block
- XS Plug
- XP Receptacle
- VV Solenoid valve

CODE TO NUMBER AUXILIARY CONDUCTORS
(ABCD)

- AB = page's number
- CD = progressive conductor's number

CODE TO INITIALLING FOR ELECTRIC EQUIPMENT
(A B C)

- A = page's number
- B = device designation
- C = progressive's number

CODE TO LOCATE OF RELAY CONTACTS
(A . B)

- A = page's number
- B = column's number

CODE TO REFER LINE
(A / B)

- A = page's number
- B = column's number and letter's line

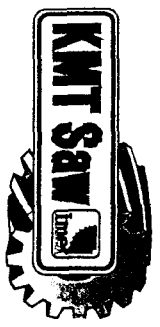

KALAMAZOO MACHINE TOOL

CT 350 A-NC

DISEGNO N° : QE0136C2	
FILE	:
Dato	: 02.2001
Foglio N°	: 1/14
23	24
25	26
27	28

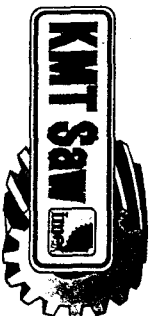
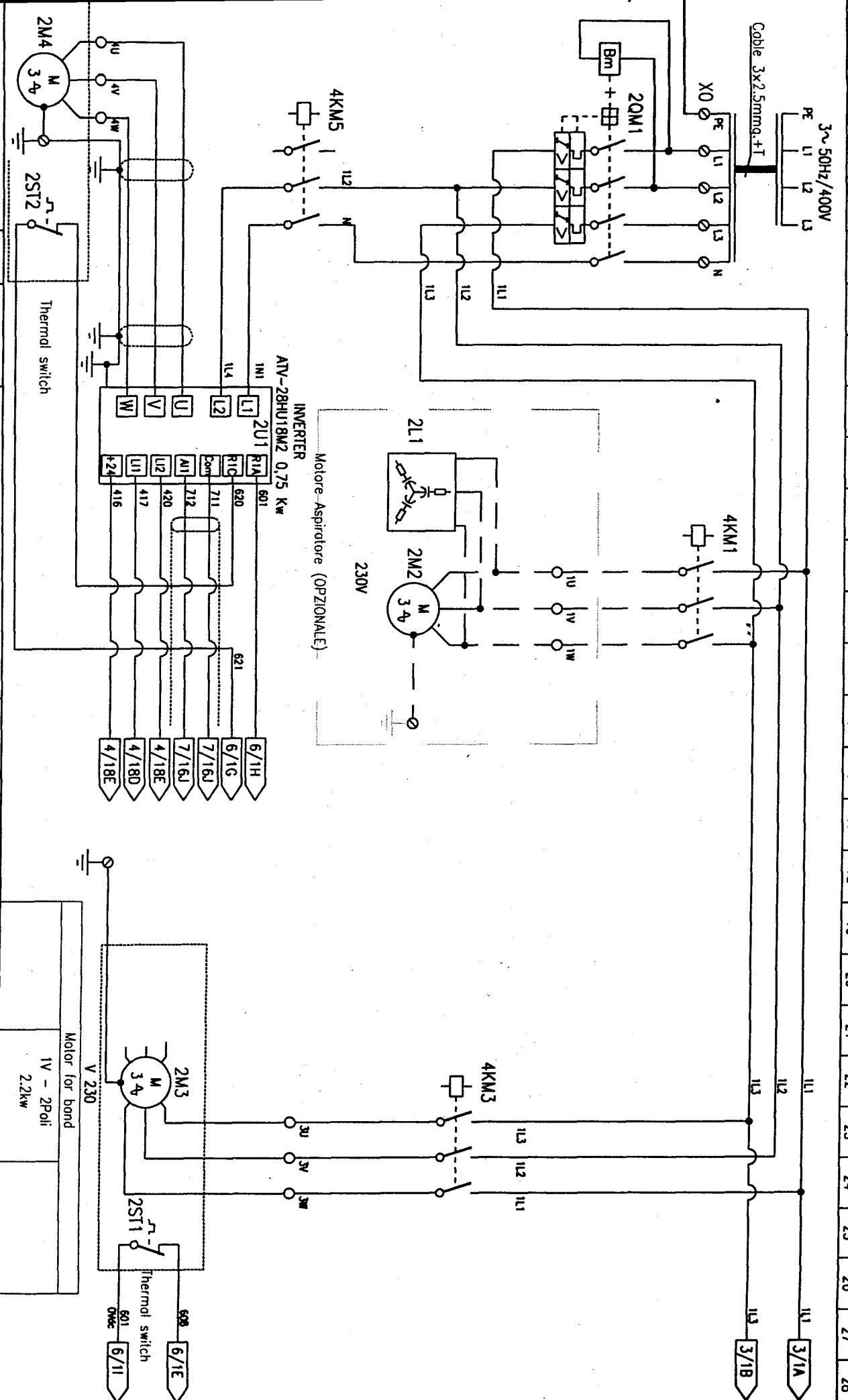

KALAMAZOO MACHINE TOOL

CT 350 A-NC

23	24	25	26	27	28
DISEGNO N° : QED0136C2 FILE : Data : 02.2001 Foglio N° : 2/14					

Motor for band	
1V - 2Poli	2.2kW

2/28A

2/28B

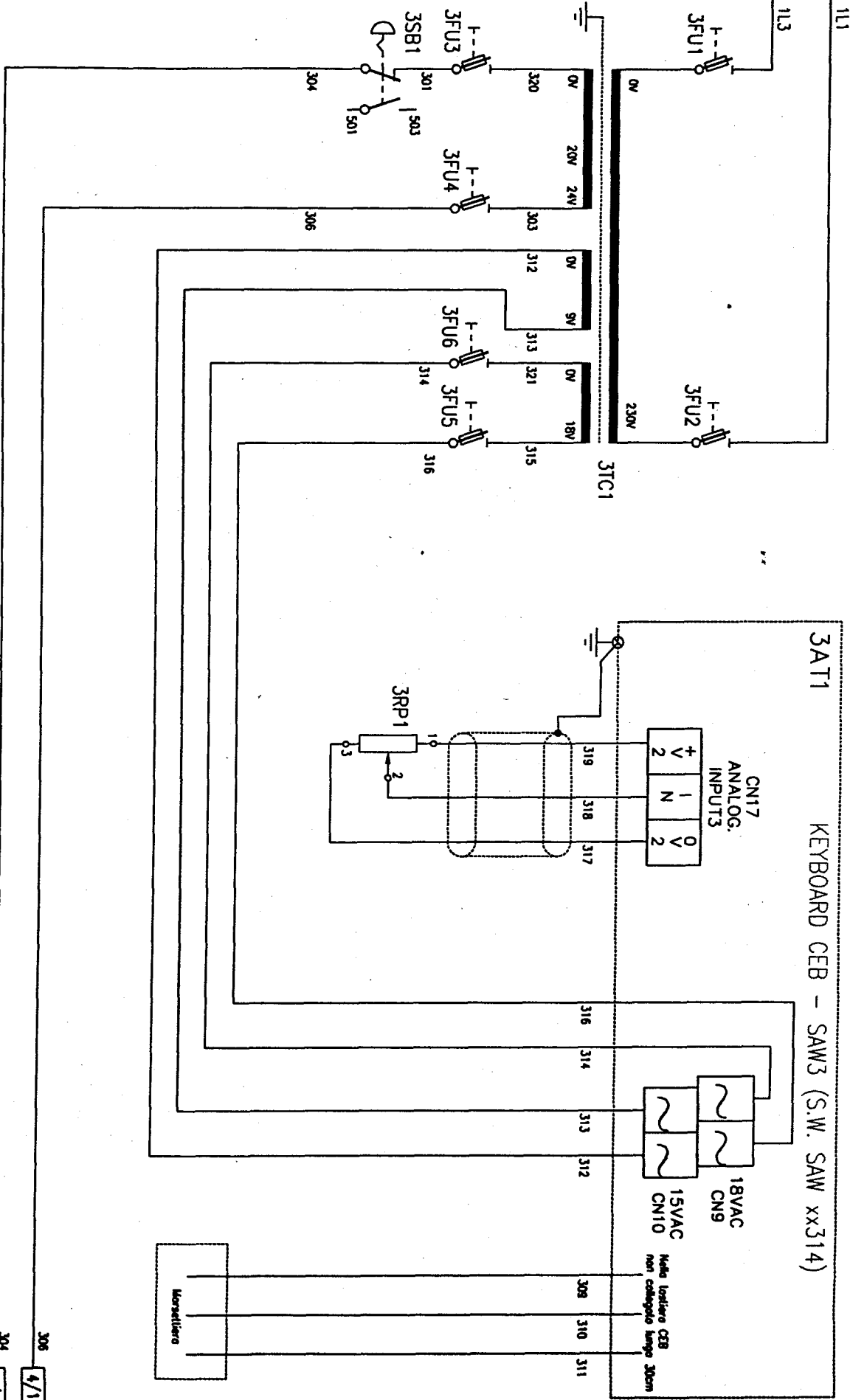

KALAMAZOO MACHINE TOOL

CT 350 A-NC

DISSEGNO N° :	QE0136C2			
FILE :				
Data :	02.2001			
Foglio N° :	3/14			
23	24	25	26	27

306 4/10
304 4/11

3A/T1 KEYBOARD CEB - SAW3 (S.W. SAW xx314)

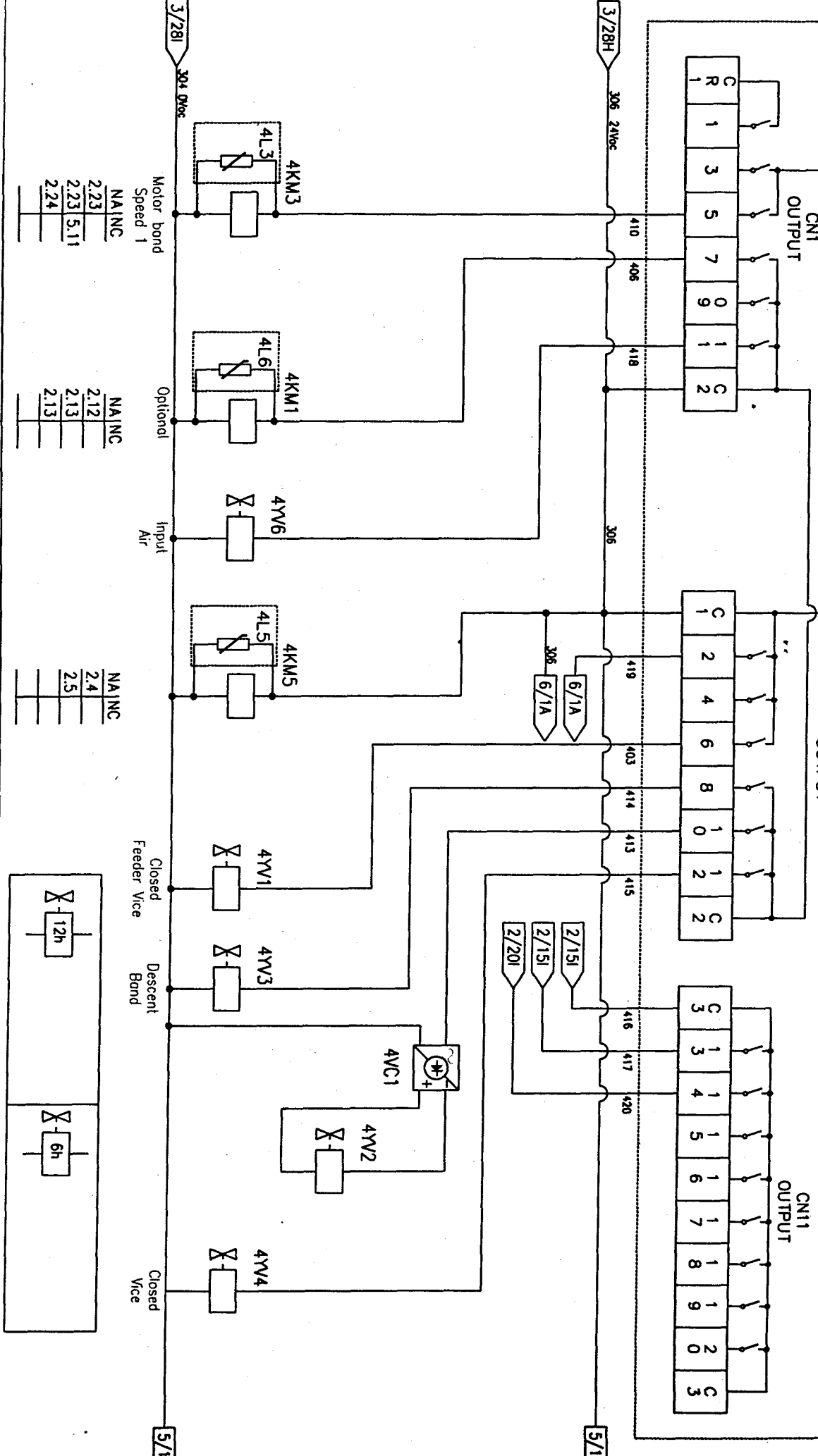

2.23	NA/NC
2.23	5.11
2.24	

2.12	NA/NC
2.13	
2.13	

2.4	NA/NC
2.5	

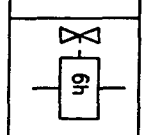
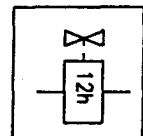

KALAMAZOO MACHINE TOOL

CT 350 A-NC

DISEGNO N° : QE0136C2	
FILE	:
DATA	: 02.2001
Foglio N°	: 4/14
23	
24	
25	
26	
27	

1 2 3 4 5 6 7 8 9 10 11 12 13 14 15 16 17 18 19 20 21 22 23 24 25 26 27

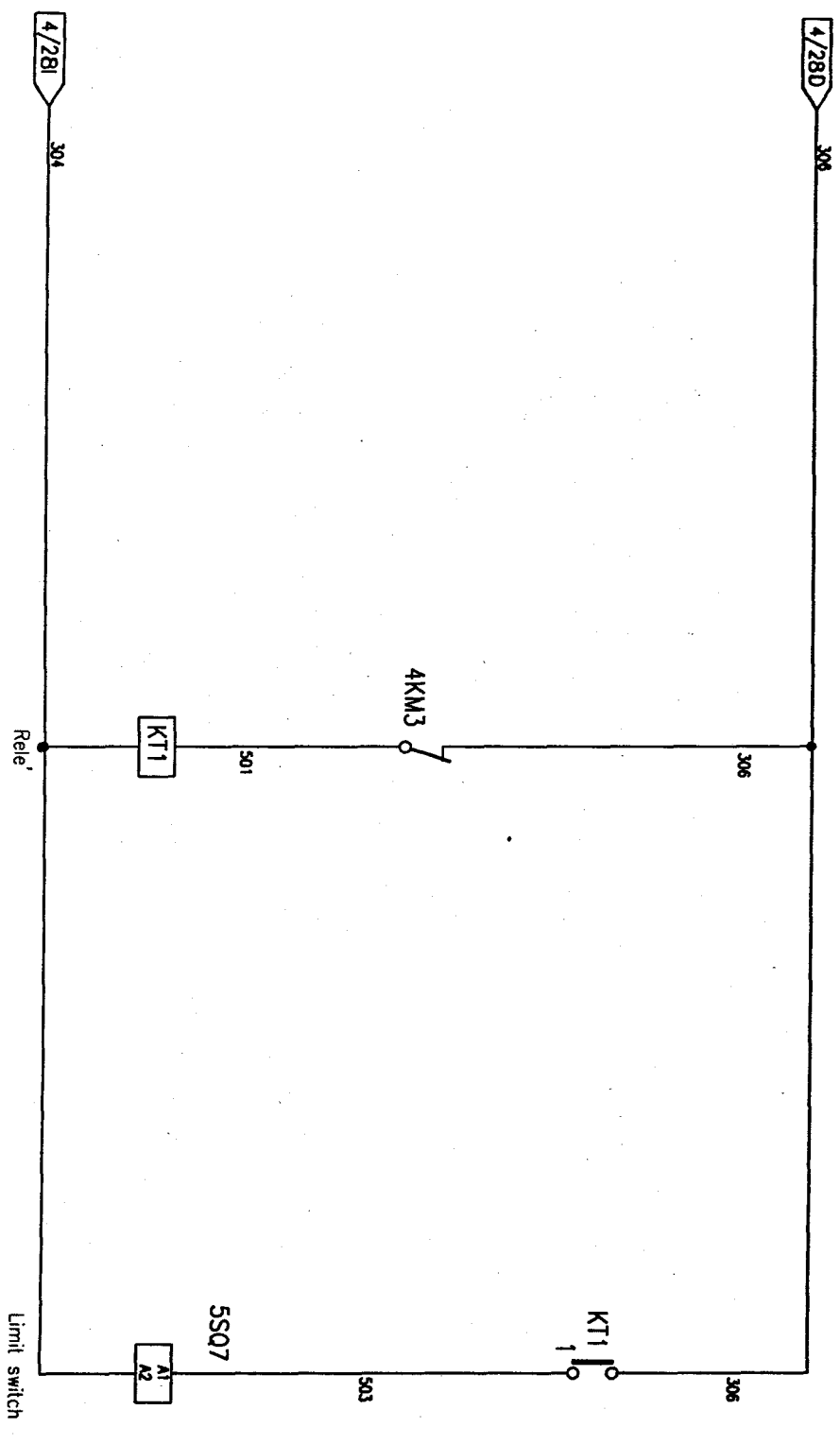

NA	NC
5.19	



KALAMAZOO MACHINE TOOL

CT 350 A-NC

23	24	25	26	27
DISEGNO N° : QE0136C2				
FILE :				
Data : 02.2001				
Foglio N° : 5/14				

3AT1

KEYBOARD CEB - SAW3 (S.W. SAW XX314)

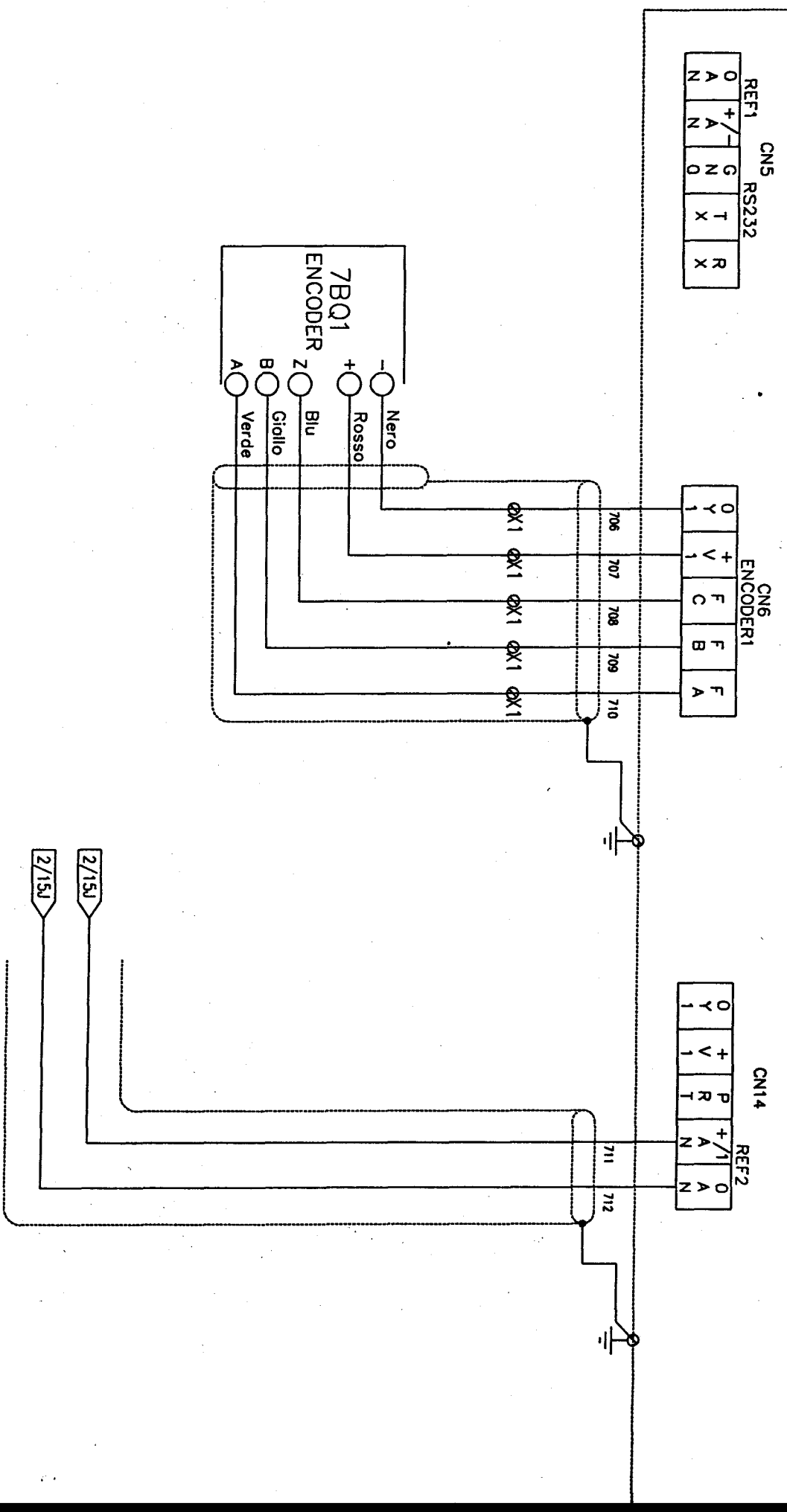

KALAMAZOO MACHINE TOOL

CT 350 A-NC

DISIGNO N° :	QE0136C2			
FILE :				
Data :	02.2001			
Foglio N° :	7/14			
23	24	25	26	27

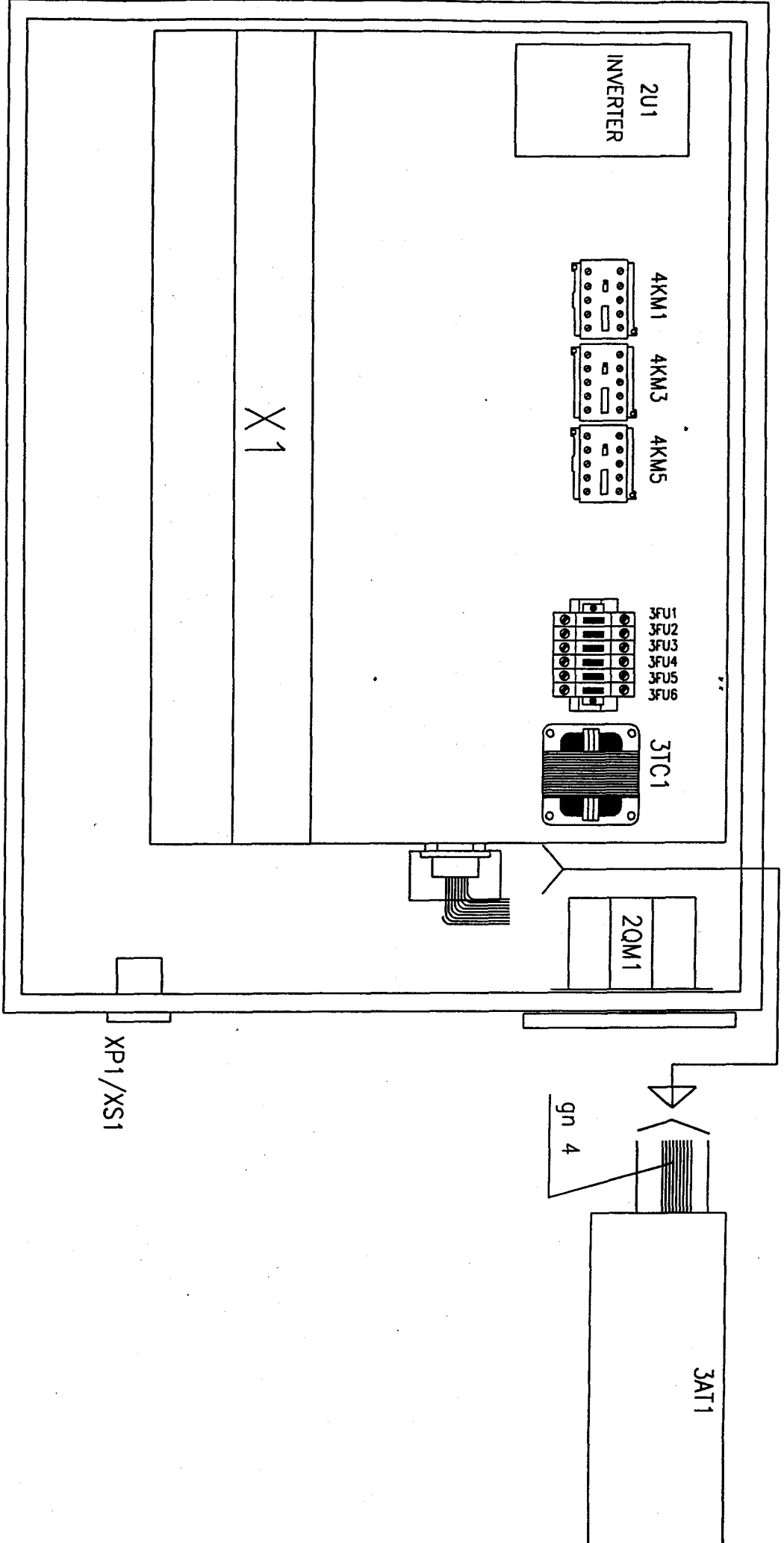

KALAMAZOO MACHINE TOOL

CT 350 A-NC

23	DISSEGNO N° :	QE0136C2
24	FILE :	
25	Data :	02.2001
26	Foglio N° :	9/14
27		

REF.	DEVICE	SPECIFICATIONS	FUNCTION	FACTORY	TYPE	ITEM N°	Q.
20M1	Circuit breaker	3P-P.L. 9-14A-Reg. 13A	Main circuit breaker	TELEMECANIQUE	GV2 M16 9-14A	766170	1
20M1	Min. voltage relay	230V	Unloeh main circuit	TELEMECANIQUE	GV2 AU225	164906	1
20M1	Terminal box	IP55	Terminal box for main circuit breaker	TELEMECANIQUE	GV2 MP02+V01	766198	1
2M2	OPTIONAL	230V	OPTIONAL	BRIANZA ASPIRA	FC71 B5 2 POLI		1
2M3	Motor	230V 60Hz		ELETTROADDA	FC90 2P	565498	1
2L1	Filter (optional)	RC + Cavo 575V	Noise suppressor	MPM	130809	334010	1
4L3	Filter	Voristore	Noise suppressor	SIEMENS	3RT1916-1JU00	334580	1
4L5	Filter	Voristore	Noise suppressor	SIEMENS	3RT1916-1JU00	334580	1
4L6	Filter	Voristore	Noise suppressor	SIEMENS	3RT1916-1JU00	334580	1
2ST1/2ST2	Thermal switch	Classe B	Protection overload motor bond	TERMIK			
2L1	Filtro (Opzionale)	RC + Cavo 575V	Antidisturbo	MPM	130809	334010	1
7B01	Encoder	4m di cavo	Feeder carriage position	ELTRA	EL40A2000Z5/28C6X3	331770	
3A11	Station control CEB	IP65	Contro unity and program	C.E.B.	SAW3	918685	1
3RP1	Potenzimetro	5kOhm/308/± 0.3%/IP65	Controllo Discesa Lomo	SICK	SP2841001941	699743	1
3FU1	Fuse block	1 Polo /20A 500V	Primary protection transformer	LEGRAND	01127	694500	1
3FU1	Fuse	10x38mm./calibro 2A	Primary protection transformer	WEBER	10X38mm./2A	390111	1
3FU2	Fuse block	1 Polo / 20A 500v	Primary protection transformer	LEGRAND	01127	694500	1
3FU2	Fuse	10x38mm./calibro 2A	Primary protection transformer	WEBER	10X38mm./2A	390111	1
3FU3	Fuse block	4mmq./6.3A	Primary protection transformer	WEBER	STK 1 PA	694520	1
3FU3	Fuse	5x20mm./calibro 6.3A	Primary protection transformer	WEBER	5x20mm./6.3A	390001	1
3FU4	Fuse block	4mmq./6.3A	Primary protection transformer	CUNTACLIP	STK 1 PA	694520	1
3FU4	Fuse	5x20mm./calibro 6.3A	Primary protection transformer	WEBER	5x20mm./6.3A	390001	1
3FU5/6	Fuse block	4mmq./6.3A	Primary protection transformer	CUNTACLIP	STK 1 PA	694520	1
3FU5/6	Fuse	5x20mm./calibro 3.2A	Primary protection transformer	WEBER	5x20mm./3.2A	390001	1

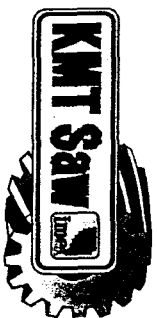

KALAMAZOO MACHINE TOOL

CT 350 A-NC

DISIGNO N° :	QE0136C2
FILE :	
Date :	02.2001
Foglio N° :	10/14

23	24	25	26	27
----	----	----	----	----

REF.	DEVICE	SPECIFICATIONS	FUNCTION	FACTORY	TYPE	ITEM N°	Q.TY
3FU7	Fuse block	4mmq./6.3A	Primary protection transformer	CUNTACLIP	STK 1 PA	694520	1
3FU7	Fuse	5x20mm./calibro 3.2A	Primary protection transformer	WEBER	5x20mm./3.2A	390001	1
3TC1	Control circuit transformer	VA160/VAe 230 Vw1 0-20-24	Main auxiliori supply				
3SB1	Pushbutton (emergency)	ø40mm. - Sblocco o rotazione	Emergency stop button	BRETER	RM 065R	709170	1
3SB1	Normally closed contact	NC - Rosso	Emergency stop button	CEMA	P9XER4RN		
3SB1	Normally open contact	NC - Verde	Emergency stop button	BRETER	V 40 +P24417R	260231	1
2U1	Inverter	230V 0.75Kw	Variatore di frequenza	CEMA	P9B01UN		
4KM1	Control master relay	4KW-9A-24Vdc	Power coolant	BRETER	V 50 + P24418V	260397	1
4KM1	Control master relay	4KW-9A-24Vdc	Power coolant	CEMA	P9B10UN		
4KM3	Control master relay	5.7KW-12A-24Vdc	Power coolant	TELEMECANIQUE	ATV-28HU18M2	521255	1
				LOVATO	MC9-10 24V	260750	
				LOVATO	BF12-01 24V	260783	1
4VC1		AC/DC 24V		MPM	S11209NR021	261175	1
4V1	Solenoid valve 5/2	1/8" SOTTOBASE 24Vdc	Control				1
4V2	Solenoid valve 2/2	CARTUCCIA M22 24V dc	Control				1
4V3	Solenoid valve 5/2	1/8" SOTTOBASE 24Vdc	Control				1
4V4	Solenoid valve 5/2	1/8" SOTTOBASE 24Vdc	Control				1
4V6	Solenoid valve 3/2	1/8" SOTTOBASE 24Vdc 3 VIE	Control				1

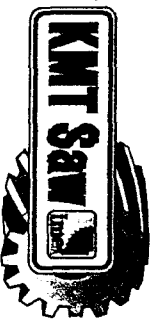

KALAMAZOO MACHINE TOOL

CT 350 A-NC

DISSEGNO N° : QE0136C2
FILE :
Data : 02.2001
Foglio N° : 11/14
23
24
25
26
27

REF.	DEVICE	SPECIFICATIONS	FUNCTION	FACTORY	TYPE	ITEM N°	Q.T.
5SP1	Pressostato	1/8" - 0.15 Bar NO	Controllo ingresso orio	ELETTROTEC	PMN 2A T1	699897	1
5S02	Fincorsa Magnetico	IP65 completo di cavo	Controllo chiusura morso	MPM	DCB1B425+DST51+...	774275	1
6SQ3	Limit switch	IP65 completo di cavo L.350	Control	TELEMECANIQUE	XGMA1023	521145	1
6SQ4	Limit switch	IP65 completo di cavo L.350	Control	TELEMECANIQUE	XGMA1023	521145	1
6S05	Limit switch	Rotello	Control	PIZZATO	FR38+LE553	521100	1
6S06	Limit switch	IP00 NO/O/NC	Control	PIZZATO	MS 06	520916	1
5S07	Limit switch	IP65	Control	PIZZATO	F5694-D24F	520700	1
X2	Terminal block	Morsetti terra Giallo/Verde	Connections external equipments	CONTRACIP	SL 4	559090	3
X2	Terminal block	Single terminal 2.5mmq/4A	Connections external equipments	CONTRACIP	RK 2.5 4PA	558790	48
XS1	PULG NOT SUPPLIED	4 Pol./10A+Terra	Remote control	ILME	CK03V+CKM04	786745	1
XP1	Receptacle	4 Pol./10A+Terra	Remote control	ILME	CK31A+CKF04	699750	1
X2	Terminal block	Morsello d'estremita'	Connections external equipments	CONTRACIP	ES35	558810	3
cw0	Flexible cable	4x2.5mmq.	Connection main supply			205213	
cv1	Flexible cable	1x1.5mmq. Schermato	Connection solenoid valves and limits switch				
cv2	Flexible cable	4x1.5mmq.	Connection solenoid valves and limits switch				
cv3	Flexible cable	1x1.5mmq.	Connection solenoid valves and limits switch				
cv4	Flexible cable	3x0.25mmq. Schermato	Connection solenoid valves and limits switch				
cv5	Flexible cable	2x0.75mmq.	Connection solenoid valves and limits switch				
cv6	Flexible cable	2x0.75mmq.	Connection solenoid valves and limits switch				
cv7	Flexible cable	2x0.75mmq.	Connection solenoid valves and limits switch				
cv8	Flexible cable	2x0.75mmq.	Connection solenoid valves and limits switch				
cv9	Flexible cable	2x0.75mmq.	Connection solenoid valves and limits switch				
cv10	Flexible cable	2x0.75mmq.	Connection solenoid valves and limits switch				
cv11	Flexible cable	2x0.75mmq.	Connection solenoid valves and limits switch				
cv12	Flexible cable	2x0.75mmq.	Connection solenoid valves and limits switch				
cv13	Flexible cable	4x2.5mmq. Schermato	Connection solenoid valves and limits switch				
cv14	Flexible cable	2x0.75mmq.	Connection solenoid valves and limits switch				
cv15	Flexible cable	2x0.75mmq.	Connection solenoid valves and limits switch				

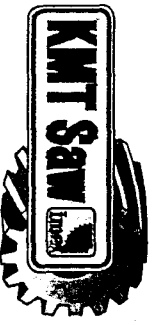

KALAMAZOO MACHINE TOOL

CT 350 A-NC

S.A	DISCENO N° : QE0136C2
FILE	:
nts	Date : 02.2001
ci	Foglio N° : 12/14
23	24
25	26
27	

